

# Illuminated Magnilites®

## Vision-Lite® 2000

Our Vision Brings You Into The 21st Century

WHITE LIGHTS®  
O.C. White Co.  
Quality Since 1894

VISION LITE®  
MAGNILITES®



ALSO AVAILABLE  
IN 2X  
MAGNIFICATION



#72400EZ-GFW

Patent #5,757,142

**ERGONOMIC**

The Vision Lite® 2000 is the **world's first dimmable fluorescent illuminated magnifier**. New "Patented" **state-of-the-art microchip** controlled ballast technology allows the Vision Lite 2000 to be dimmable from 100% down to 25%, so that highly reflective surfaces can easily be seen by dimming the units exclusive "Glare-Free" bulb.

An exclusive slide switch allows the operator to change illumination intensity with the stroke of a finger. This bulb's unique design provides three-sided illumination, eliminating annoying shadows that are associated with magnifiers that have only two-sided, or left and right-sided bulbs. It also **eliminates all fluorescent flickering**, reducing eye fatigue.



The Vision Lite 2000 boasts one of the **largest 46.5 sq. inch (7.5"X 6.2")** and **clearest 3 diopter (1.75X-1.85X) lenses** available for any magnifier product. It is also equipped with an **ESD safe shade**.

Options include our **4 diopter lens (2X)** or our excellent anti-reflective coating (A/R) to reduce overhead glare, or our exclusive U.V. bulb to inspect conformal coating or plating voids.



#72400

- ESD safe construction
- Ergonomic
- 3 diopter 7.5" x 6.2" lens (1.75-1.85x)
- 43" reach
- Clamp-on
- Standard Glare-free bulb (#13392)
- White finish
- UL/cUL/CE



#71600 BLACK

- ESD safe construction
- Ergonomic
- 3 diopter 7.5" x 6.2" lens (1.75-1.85x)
- 25" reach
- 38 lb. weighted portable base
- Standard Glare-free bulb (#13392)
- Black finish
- UL/cUL/CE



#13226

- UV impregnated plastic
- Easy clip-on
- Protects bulb
- Optional
- Clear

#14161

- 10 diopter add on lens to boost magnification power.

**NEW**

O. C. White Company, Inc.  
 2039 Bridge Street, Three Rivers, MA 01080  
 Phone 413-289-1751 . Fax 413-289-1754  
<http://www.ocwhite.com>



**Features**

- ESD safe construction
- Ergonomic positioning
- Excellent 7.5" X 6.2" optical quality lens
- Exclusive shadowless wrap around bulb
- "Patented" fully variable bulb
- 34 watts @ high easily slides to approximately 7 watts
- Exclusive glare-free phosphors help reduce reflections
- Other phosphors available
- Convenient shade handles
- E-Z to use, rotatable locking handles
- E-Z Swivel®, allows sideways or angular mounting on all benches
- Anti-reflective lens coating available. Specify A/R after product # (available on 3 diopter only)
- Optional UV (365 nanometers) bulb (#13393) cool white (#13394) or yellow bulbs (#13395) available
- Industrial quality Ultraflex® arm assembly, excellent holding ability
- 10 year mechanical warranty

**Mechanical Features**

- 7.5" x 6.2" lens
- 43" reach standard
- 25" optional
- Springs (music wire)
- Bulb (U shaped), 10,000 hour life
- Steel swivel
- 1/2" square x .042" rugged arm
- Variety of bases available

**Electrical Specs**

- Low voltage (12V)
- 120 volt, 230 volt optional
- Molded 3 wire plug
- 34 watt maximum
- Electronic transformer "patented"
- UL/CUL & CE available
- 1 year warranty
- IEC cord (see chart)

**Mechanical Specs**

#72400EZ-GFW

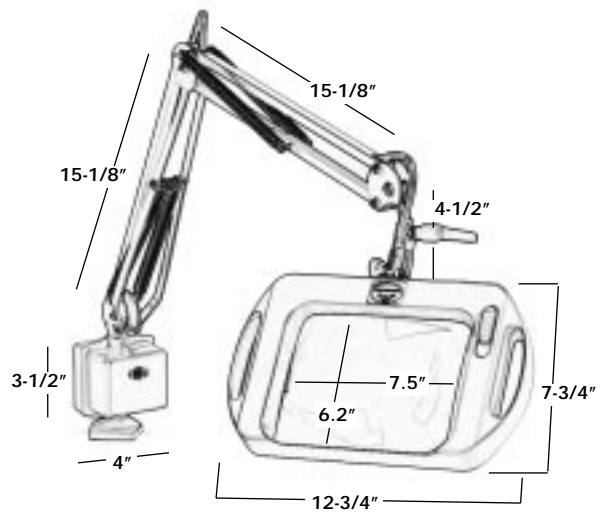

► Most Popular

Product #	Ultraflex®		Mounting Base			Bulb Type			AP	Finish		Lens Diopter			Voltage	
	25"	43"	Clamp on	Screw down	Weighted 38lb.	Cool White	Glare Free	UV Blk. Lt.		Lt. Grey	Blk.	3	3AR*	4	STD 120	OPT 230
71400GF	X		X				X			X		X		X		
71600GF Black	X				X		X				X	X		X		
72300GF		X		X			X			X		X		X		
72300GF-4		X		X			X			X			X	X		
72300GF-AR		X		X			X			X		X		X		
72400GF-Black		X	X				X				X	X		X		
72400GF		X	X				X			X		X		X		
72400GF-4		X	X				X			X			X	X		
72400GF-AR		X	X				X			X		X		X		
72400GF-UV		X	X					X		X		X		X		

Consult factory for other models/numbers/colors not listed \* Optional colors available upon request, consult factory for details  
 \* For black specify after part # \* For 230 volt products select cord type from chart  
 \* Anti-reflective coating (Specify A/R) \* For optional bulbs specify CW, UV or yellow after part # or "Glare-Free" supplied

[www.visionlite.com](http://www.visionlite.com)